

General Troubleshooting for Standard CX Series Generators

Note: This guide would not be appropriate for units operating with DeviceNet or for specialty products.

Current Situation:

Undoubtedly the world's most prolific user of radio frequency (RF) generators is the semiconductor equipment industry. Common practice within the semi industry is troubleshooting by swapping parts - put in a new generator and if the problem goes away ship the old one back for repair. This is a valid approach to troubleshooting assuming that the parts are available to be swapped, but the mere act of undoing all of the cables and reconnecting them to the new equipment often "solves" the problem, which was a bad cable or connection in the first place.

The Cost:

Also, in the clean room environment it is often policy that once a component is removed from local stock it cannot be returned. The result is that approximately 40% of all RF generators returned to the manufacturer for repair are diagnosed "No Fault Found." The cost of transporting, troubleshooting, and restocking these perfectly good generators is enormous.

Comdel Approach:

This troubleshooting guide is intended to aid the engineers and technicians on the firing line in determining if an apparent RF problem is in the generator or outside the generator.

In the Rack Troubleshooting:

In order to confirm or eliminate the generator as the problem in the RF system without uninstalling the generator and without disturbing any of the wiring, the first pass should be "in the rack" troubleshooting. A block diagram for troubleshooting purposes can be as simple as Figure 1:

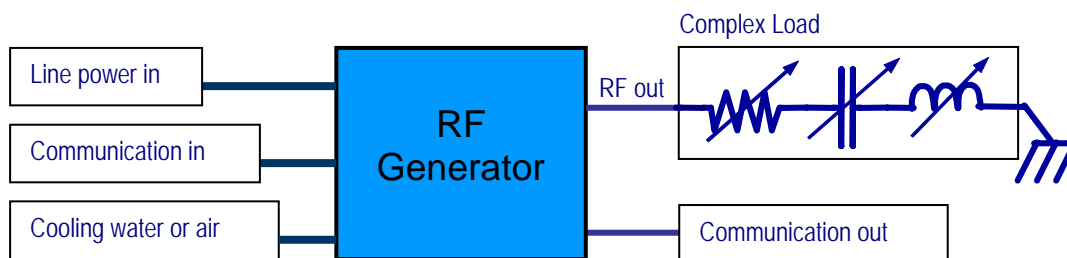

Figure 1 – RF Environment Block Diagram

Put simply, the generator can be identified as the cause of a problem only if the load and all of the inputs are what they should be and the outputs aren't. So "in the rack" troubleshooting to determine if a problem is inside or outside the generator involves systematically checking the generator inputs and the load environment. The troubleshooting guide below assumes that the generator in question is one that has been on the system and performing or is a part number that has been qualified on the system and the system has been functional with a like part number.

Comdel part numbers always start with "FP" followed by four digits, an "R" and then either a numeric or alpha character referring to the revision level. This number can be found on the serial number tag.

The first step should be to refer to the product manual for the generator in question. Product manuals can be found on Comdel's website. Use the part number as a reference to ensure that you have the proper manual. Next, operate the generator using the system controls in normal operating fashion. Refer to Figure 2 for power measurement and other front panel indicators and controls.

Tools and instruments required:

- Generator specification/manual defining the I/O for the particular generator part number
- Digital Volt Meter (DVM)
- Cable Breakout so that voltage measurements can be taken at the generator interface connector.
- An external power meter is not recommended for "in the rack" troubleshooting. Forward and reflected power information can be read on the generator display. This exercise is primarily one of observation and low level voltage measurement. If required, visual inspection of line voltage connections with circuit breaker mains OFF is adequate to inspect for proper power line input to the generator.

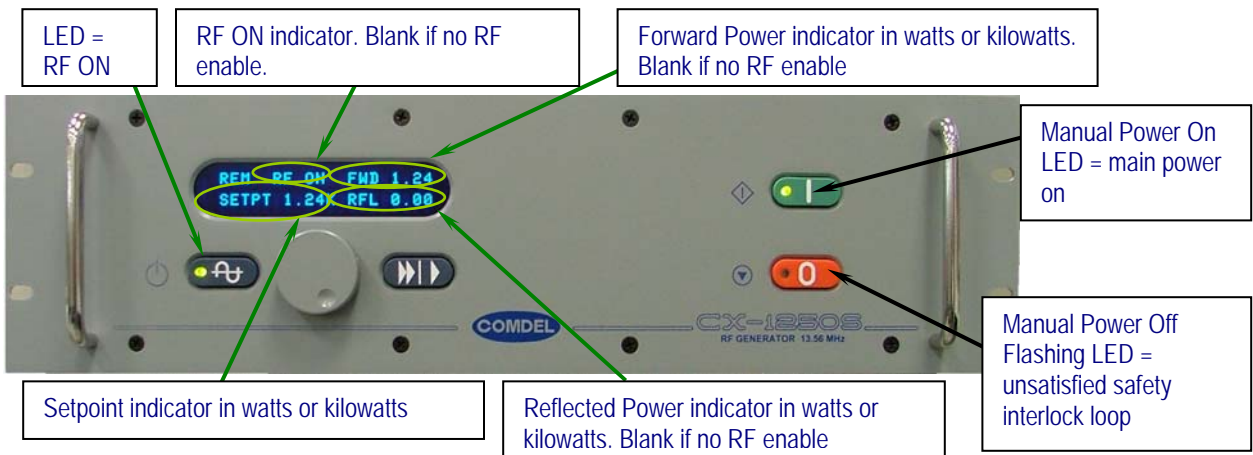

Figure 2 - Typical Comdel Front Panel - Remote Mode

NOTE: In some cases the generator is programmed to control on "delivered" power rather than forward power out. This may be hard wired in the generator or selectable via a digital input pin on the interface connector. In such a case, there will be a DEL power indicator in place of the FWD power indicator and DEL should be equal to setpoint plus RFL power.

CX Series Generator "in the rack" Troubleshooting Guide

Problem	Conditions and/or Symptom	Probable External Cause(s)
Generator won't power up	No indicator lights or display on front panel	<ol style="list-style-type: none"> 1. Generator circuit breaker off or tripped 2. Missing one or more legs of the power line
	Red flashing light on right side of front panel (indicates that the safety interlock loop is not satisfied)	<ol style="list-style-type: none"> 1. Missing RF output connector interlock cover 2. No external connection between interface pins designated as "safety interlock"
	Steady red light on right side of front panel	Generator did not autostart - possibly per specification. Push green button.
Generator powers up but no RF output.	Setpoint of "0" indicated on generator front panel display.	No setpoint input from system control
	Generator indicates proper setpoint but FWD and RFL power indicators not shown on front panel display.	No "RF enable" signal from system control
Some power out but less than requested	Reflected power is high but not nearly as high as forward power (generator is in reflected foldback)	Impedance matching ¹
	Reflected power is nearly as high as forward power (generator is in reflected foldback and almost no power is being delivered)	<ol style="list-style-type: none"> 1. A short or open circuit in the coax, the match, or the match - load connection. 2. The matching network is not in a position to ignite the plasma. 3. The chamber pressure or other parameter is not proper for plasma ignition
	Reflected power is low (or zero)	Missing one leg of the three phase line
	Setpoint on display not in agreement with analog voltage from system control (25 pin analog interface only)	<ol style="list-style-type: none"> 1. Missing ground reference on return side of differential analog input (external) 2. System noise
Requested power out but excessive reflected		Impedance matching ¹
Generator overheats	Operation is normal when generator is cool, overheating happens after some seconds or minutes of RF on.	<ol style="list-style-type: none"> 1. Excessively high ambient air temperature 2. Insufficient air circulation in vicinity of generator. 3. Insufficient cooling water flow 4. Excessive cooling water temperature
Power indicated on system controller disagrees with generator power indication (fwd or ref).	Analog interface in use (DeviceNet and RS-232 communication is not covered in this troubleshooting guide)	<ol style="list-style-type: none"> 1. Connection problem between generator analog output and system control 2. Missing ground reference on return side of differential analog output (external) 3. System noise

¹ In frequency tuning cases high reflected power can be caused by faulty tuning on the part of the generator. However, this is highly unlikely in the case of a generator that has been successfully qualified to operate into the load. All external causes of high reflected power should be ruled out before suspecting the generator.

On the Bench Troubleshooting:

If "in the rack" troubleshooting is inconclusive or if it indicates a generator problem, further investigation should be done with the generator operating independently of the system. In this case the generator can be operated in the "LOCAL" mode and the load should be a 50 ohm "dummy load." If possible, a known good RF coaxial cable should be used between the generator and the dummy load. If the generator power measurement is suspect, an external power meter can be used to measure power.

Refer to Figure 2 for previously discussed indicators and controls and to Figure 3 for local operation of the generator:

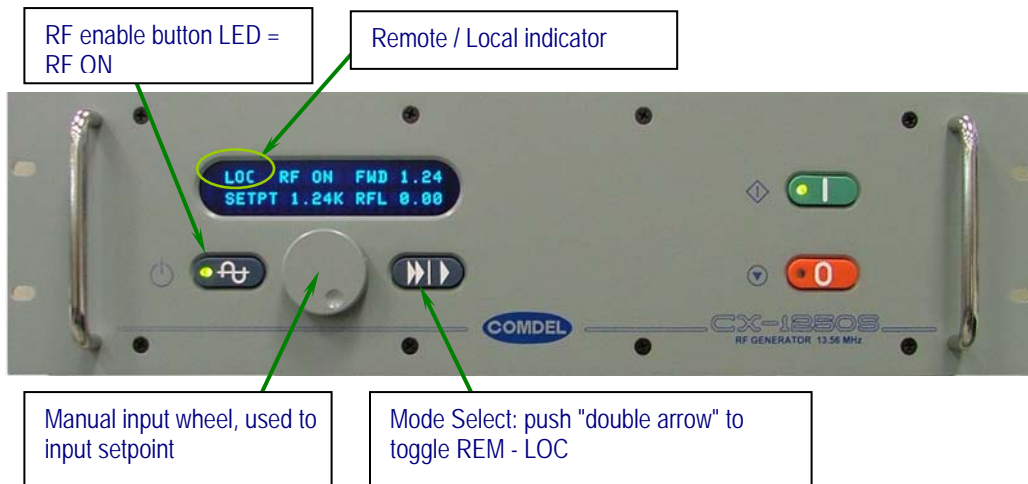

Figure 3 - Local Mode

Setup:

- Connect line power, water if needed, and dummy load with inline watt meter if desired.
- Provide safety interlock and RF enable jumpers to the generator analog interface connector. Refer to the generator specification if available (generally found at Comdel's website).
 - "Standard" 25 pin interface uses Pins 10 - 23 for safety interlock; Pins 6 - 4 and 17 - 19 for RF enable.
 - "Standard" 15 pin interface uses Pins 11 - 12 for safety interlock and Pins 4 - 9 for RF enable.
 - Lack of safety interlock will cause the red LED in the red "0" button to flash on and off. Note that the plunger associated with the RF output connector is part of the safety interlock loop. Install the cover provided or pull out on the plunger.
 - An attempt to enable RF output with the interface RF enable pins not connected will cause "Check RF Interlock" to be displayed on the front panel of the generator.

Local Operation:

- Turn on the circuit breaker in the back of the generator. In most cases the generator will "autostart" when the breaker is turned on. In the rare cases when the specification does not call for autostart, the generator is powered up by pushing the green "1" button.
- The generator powers up in the REMote mode. Toggle to LOCAL mode using the "double arrow" button.
- Dial in a setpoint using the "Manual Input Wheel."
- Push the "Sine Wave" button to enable RF output.
 - The forward power output as indicated on the generator display should equal the setpoint.
 - Reflected power should be zero or very close to zero. If this is not the case, the fault is probably NOT in the generator. The coax cable between the generator and dummy load is likely at fault.

- Forward power indicated on an external inline meter, if used, should agree with the generator's display within 3%. Note that the generator's power measuring circuitry is frequency specific and is therefore probably more accurate than the broadband peak detector circuitry in the inline watt meter.
- Analog output voltages can be measured at the generator interface connector in the LOC mode just as in the REM mode.
- Most 25 pin interfaces use differential outputs so the specified analog output pin must be measured referenced to the specified return pin and for best results ground the return pin to the generator chassis while measuring.
- Refer to the generator or system specification for scaling.

If the generator performs per specification on the bench, but not when connected to the system, then further troubleshooting of the system I/O or load environment is warranted.